

FOR SAFE FIRING  
OF BLACK LIQUOR  
IN RECOVERY BOILERS

**VAISALA**



Vaisala K-PATENTS® Digital Divert Control System DD-23

# APPLICATION



## SAFE OPERATION OF RECOVERY BOILERS REQUIRES VAISALA K-PATENTS® DIGITAL DIVERT SYSTEM

Feeding low concentrations of black liquor solids to a kraft chemical recovery boiler burner can cause a steam explosion. A digital divert control system is required to ensure safe operation.

The Black Liquor Recovery Boiler Advisory Committee (BLRBAC) recommends standards for safe firing of black liquor and suggests using an automatic black liquor divert control system to ensure that weak liquor is not fed into the boiler.

BLRBAC requires that if the black liquor concentration falls below 58%, the system shall give an audible alarm signal, and go to a diversion function to direct the black liquor flow to by-pass the boiler. A concentration value of 60% shall give an audible alarm to notify the users about the low concentration. Further-more, the control unit shall check that the difference between the two individual refractometer signals does not exceed 2%.

These close tolerances require digital circuitry which eliminates drift.



# BLRBAC SYSTEM

The digital divert control system DD-23 complies strictly with all recommendations of BLRBAC.

The DD-23 system includes two SAFE-DRIVE Process refractometer sensors in the main black liquor line, and two Indicating transmitters and a Divert control unit in an integrated panel.

As an added benefit, each refractometer is a completely independent measurement system. Each system sends a separate mA output signal, which can be used by a control system or a DCS.

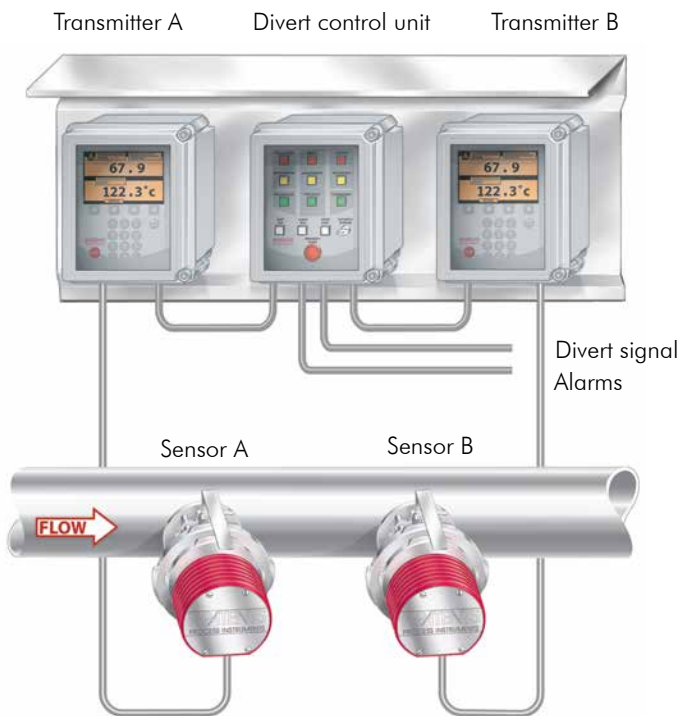

## ALL-DIGITAL DESIGN ELIMINATES FALSE DIVERT ALARMS

The divert control system DD-23 is completely microprocessor controlled. The digital signal transmission and microprocessor implemented diagnostics ensure error free operation. The system eliminates false alarms, because it reacts only when the level of solids truly falls below the safe limit. The DD-23 helps avoid costly process shut-downs resulting from unwarranted divert actions.

There is a separate power supply for each refractometer.

# RETRACTABLE SAFE-DRIVE SENSOR

The SAFE-DRIVE Process refractometer sensor is installed with SAFE-DRIVE Isolation valve (Patent pending) that allows for safe and easy insertion and retraction of the refractometer under full operating pressure without having to valve off the liquor piping or having to shut down the process. The SAFE-DRIVE Isolation valve contains a steam wash system for automatic prism cleaning.

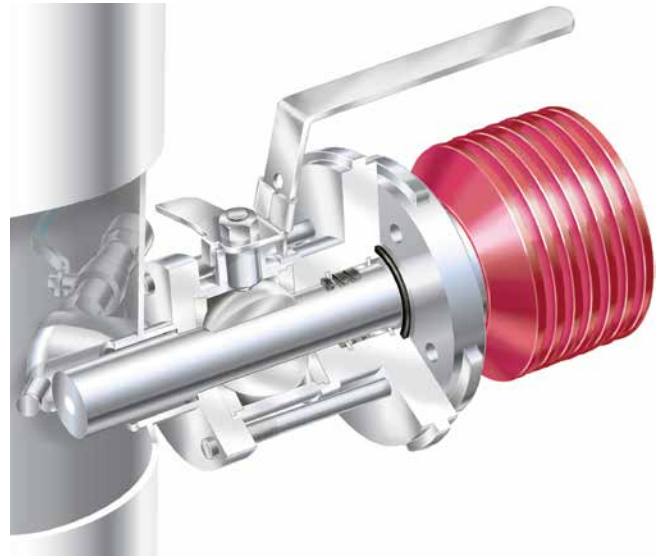

## THE UNIQUE SAFETY ASPECTS OF THE SAFE-DRIVE ARE:

- Accidental opening or closing of the ball valve is prevented.
- Easy-to-place and self-retaining design for safe insertion and retraction.
- The casing secures the user from accidental spills during the insertion and retraction.
- Triple sealing by two lip seals and an O-ring.
- The retractable prism wash nozzle can be safely removed for service checks.

# DIVERT DECISION LOGICS

## 1. ALARMS

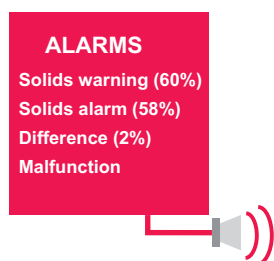

The divert decision is controlled by the divert control unit. The built-in logic provides three levels of decision rules for tight control.

**The first control level** contains four alarms indicating the following:

- Black liquor solids warning at 60%; notifies the user about the low concentration
- Black liquor solids alarm at 58%.
- Refractometer difference; the signal between the two individual refractometers must not exceed 2%.
- Refractometer malfunction alarm; is initiated, if a refractometer is malfunctioning.

## 2. STATUS OF REFRACTOMETERS

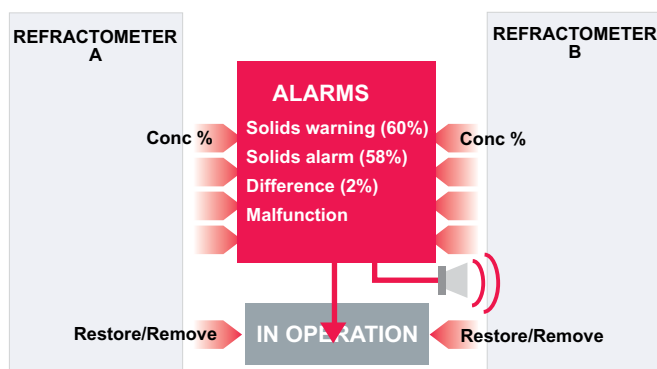

**The second control level** controls the status of each refractometer. The solids warning, the solids alarm and refractometer malfunction alarm are initiated by either refractometer A or B. The divert control unit checks that the difference between the two individual refractometer signals does not exceed 2%.

Unnecessary and false divert alarms are avoided by the following interlocks:

- A refractometer can initiate an alarm only when it is operating.
- Alarm for refractometer malfunction can only be initiated if both refractometers are operating.

## 3. DIVERT DECISION

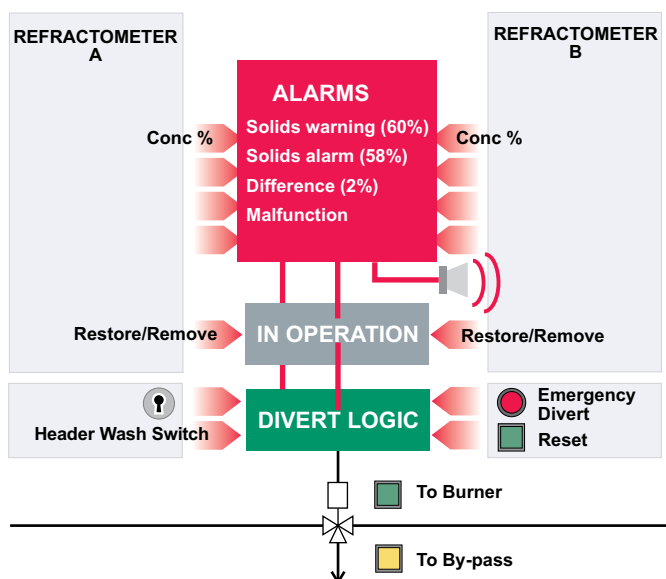

Due to the built-in intelligent diagnostics, the status of each refractometer is tightly controlled in the divert operation. A malfunctioning refractometer is automatically removed from operation.

**The third control level** consists of the actual divert decision rules. According to these rules the black liquor flow is directed either to the burner or to the by-pass line.

With the Emergency Divert button the divert can be manually initiated in an override or in an emergency situation. The Reset button resets the divert action.

For increased safety, there is a lockable override function. The override function is only available when the Header Wash Switch is activated.

# REMOTE FUNCTIONS



## EVENT DATA LOGGING

All signals and communication in the DD-23 system are digital and therefore can be used for data logging and remote monitoring via Ethernet.

The DD-23 records a full history of event data such as emergency diverts, divert resets, warnings, alarms, parameter and configuration changes, malfunction data and the states and changes of external contact inputs.

## REMOTE MONITORING

The Remote Divert User Interface DI brings a compact and easy-to-use remote display to the control room. This enables centralized management of all divert system data.

The remote user interface features a 10" graphical touchscreen color display, real-time measurement values and diagnostic information, system and instrument status, warnings and alarms, and full event log records. The panel below contains a header wash key and push buttons for divert and divert reset operations.

# SPECIFICATIONS

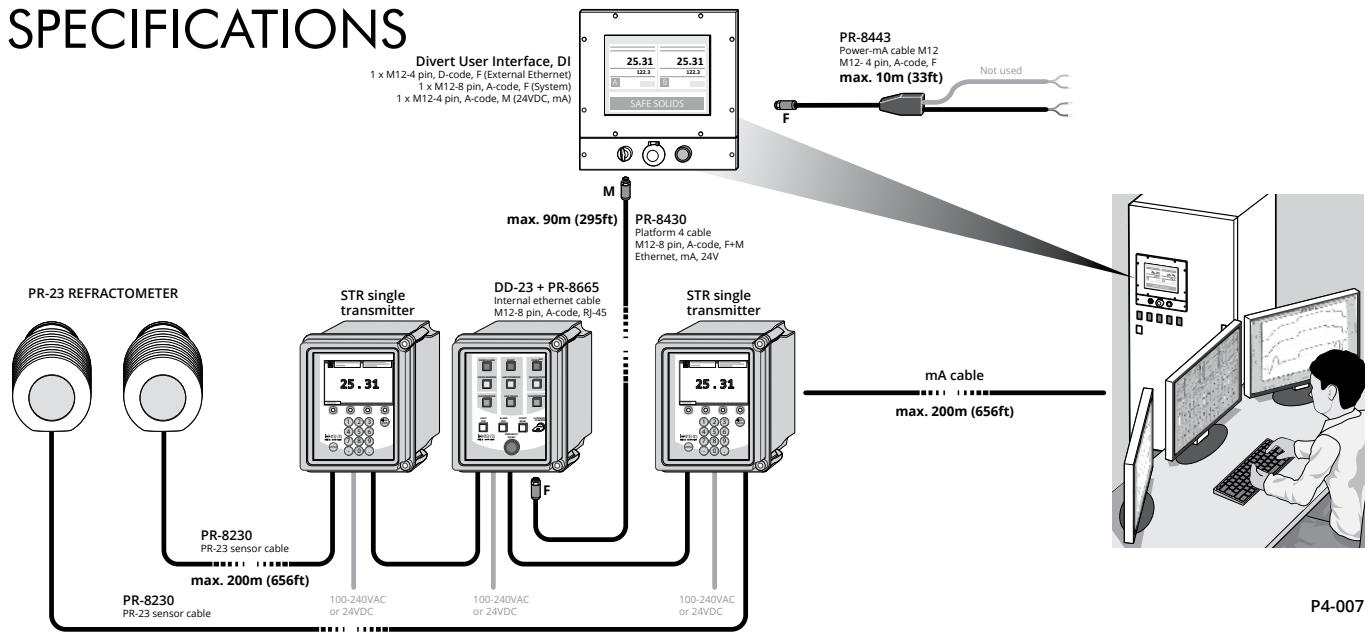

P4-007

DD-23 Digital Divert Control System fully complies with all principles of Recommended Good Practice for Safe Firing of Black Liquor in Black Liquor Recovery Boilers by BLRBAC.

## DD-23 SYSTEM COMPONENTS:

- Two SAFE-DRIVE Process Refractometers PR-23-SD (A and B) with Isolation ball valves SDI-23 and with automatic prism wash system.
- DD Divert Control Unit including an operator panel and control logics. Provides contact outputs for warnings and alarms and inputs for system control.
- The indicating transmitters and the divert control unit are mounted in a stainless steel roofed mounting plate. Wiring between the transmitters and the control unit is included.
- SAFE-DRIVE Retractor tool SDR-23 for safe sensor insertion and retraction.

## DD-23 SYSTEM FEATURES:

Refractometer measurements:	The refractometers provide separate mA measurement signals that are independent of the divert control system.
Isolation valve process connection:	By welding to pipe sizes of 2"-24" or via a spool piece (diameter of 2"-20"). Can be mounted on either horizontal or vertical pipe lines.
Spool piece process connection option:	Contact manufacturer for Spool piece options.
Prism wash:	Automatic prism wash system with steam, complete with nozzle and two check valves; one for prism wash, one for stuffing box flush. The steam wash nozzle is retractable and can be removed for service check.
Alarms and contact functions:	Warning and alarm relays for low solids and refractometer difference. Relays for instrument and system status. Header wash switch. Contact inputs for external divert switch and hard-wired divert reset.
Event log:	All user actions, system status changes, parameter changes, alarms, and warnings are recorded into an event log. The full event log is available through the remote display; a compact version can be viewed on the transmitter.
Remote functions:	Remote monitoring using Remote Divert User Interface DI. Data of real-time measurement, divert condition, measurement values, diagnostic messages and event log records remotely available to control room via Ethernet connection. Anodized aluminum enclosure, 10" graphical touchscreen color display. Optional panel for remote header wash key and push buttons for divert and divert reset operations. Wall, panel and table top mounts.



www.vaisala.com

Please contact us at  
[www.vaisala.com/requestinfo](http://www.vaisala.com/requestinfo)

Ref. B211891EN-A © Vaisala 2020

We reserve right to technical alterations.

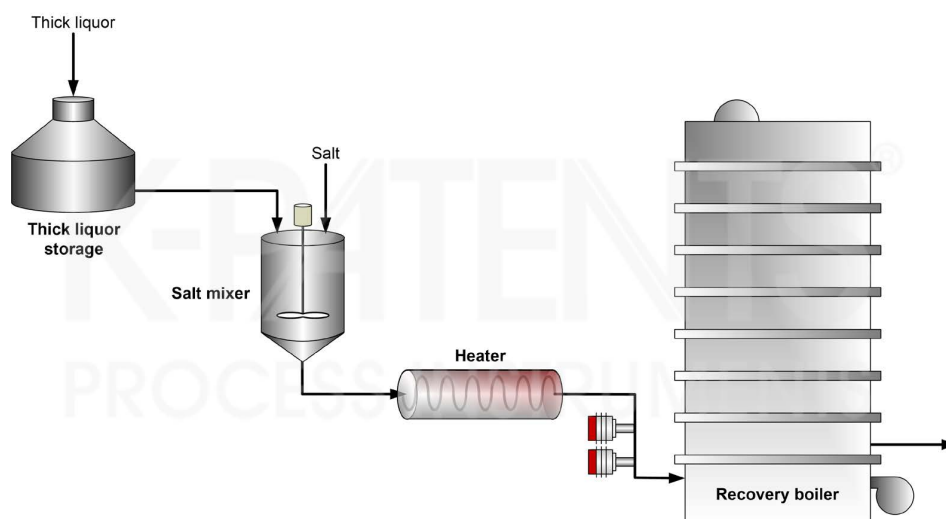

## BLACK LIQUOR

### Typical end products

Wood pulp, paper, board.

Chemical curve: R.I. per Black liquor Conc% at Ref. Temp. of 20°C

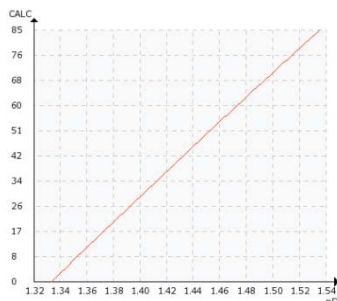

### Introduction

The recovery boiler plays a central role in the chemical cycle of a modern pulp mill. The recovery boiler is a chemical reactor, which is used for recovering chemicals from spent kraft liquor and generating energy at the same time.

In the recovery boiler, the organic matter is burned. The dry solids liquor content required for firing is at least 60% but preferably more than 65%. Black liquor is concentrated by evaporating water from the liquor. When the concentration of black liquor is maximized, so is the energy production. Before entering the burners, glauber salt is added to cover chemical losses.

### Application

The liquor should have a high content of combustible dry solids in order to minimize flue gas emissions and maximize boiler efficiency.

Too low a concentration of dry solids fed to the burners may result in a steam explosion with consequent damage or destruction to the boiler. Therefore, it is essential to utilize a refractometer to monitor the black liquor feed to the recovery boiler for safety reasons.

### Instrumentation and installation

The K-Patents Digital Divert Control System DD-23 complies strictly with all recommendations of the Black Liquor Recovery Boiler Advisory Committee (BLRBAC).

The DD-23 system includes two SAFE-DRIVE™ Process Refractometer sensors in the main black liquor line, two indicating transmitters and a divert control unit in an integrated panel.

The K-Patents SAFE-DRIVE Sensors are installed using a SAFE-DRIVE™ Isolation valve (Patent pending). This allows for safe and easy insertion and retraction of the refractometers under full operating pressure, without having to valve off the liquor piping or having to shut down the process. The SAFE-DRIVE Isolation valve contains a steam wash system for automatic prism cleaning. The system contains a SAFE-DRIVE™ Retractor Tool SDR-23 for safe sensor insertion and retraction.

Each refractometer is a completely independent measurement system. Each system sends a separate mA output signal, which can be used by a control system (PLC or DCS). The DD-23 system is entirely microprocessor controlled. The digital signal

transmission and microprocessor implemented diagnostics ensure error free operation.

Instrumentation	Description
	<p>K-Patents Digital Divert Control System DD-23 for safe operation of kraft chemical recovery boiler. K-Patents DD-23 system complies strictly with all recommendations of BLRBAC. The DD-23 system includes two K-Patents SAFE-DRIVE Refractometer PR-23-SD sensors in the main black liquor line, and two Indicating transmitters and a Divert control unit in an integrated panel. Remote monitoring and event data logging via Ethernet.</p>
<p><b>Measurement range</b></p>	<p>Refractive Index (nD) 1.3200 – 1.5300, corresponding to 0-100 % by weight.</p>